



# Austin 7 Club of S.A.

70<sup>th</sup> Anniversary 1953-2023

**Bulletin Number 185**

**17.11.23**



# **What's on and What's not.**

**17.11-19.11.23 Adelaide Rally**

**18.11.23 Working Bee 10 am to prepare for new floor.**

**19.11.23 Breakfast Run**

**27.11.23 Technical Night Subs & Rego**

**10.12.23 Christmas Dinner at Mawson Lakes**

**11.12.23 Monthly Meeting Subs & Rego**

**8.1.24 Committee Meeting**

**15.1.24 General Meeting**

**20.1.24 TTM EOS Dinner**

**26.1.24 Australia Day Event**

**12.2.24 General Meeting**

**18.2.24 Day Run**

**26.2.24 Technical Night**

**27.2.24 50<sup>th</sup> Anniversary of Clubrooms**

**14.4.24 Gawler Club Veteran & Vintage Run.**

**Please check with the organisers as dates and events may be subject to change.**

# Page 3 Girl



# Sports and Specials



David Lowe Photograph

**John Fleming at Templestone**



ADELAIDE  
AUTOEXPO



# Aussie Classics & Muscle Car Cruise

From the Adelaide Auto Expo  
Friday night November 17th  
Enter the Leader St gates at the  
Wayville Showgrounds from 5pm  
Cruise leaves at 9pm

Only \$10 each per person

Phone Geof on 0410 356 356

for more details

*Charger*



2023

# Extreme

Auto Expo

You're invited to the  
Extreme Auto Expo

## CARS & COFFEE

Saturday November 18th

Entry is 8am to 9.30am via the Rose Tce gates. The event is in front of the Jubilee

Pavilion at the Adelaide Showgrounds.

VIP entry to the show from 9am,  
1 hour before the public.

**\$5 discount off your entry ticket.**

WAYVILLE SHOWGROUNDS ADELAIDE  
Friday Night November 17th &  
all day Saturday November 18th



[www.extremeautoexpo.com.au](http://www.extremeautoexpo.com.au)





MG CAR CLUB VICTORIA  
Venue of the first Victorian & Australian Hillclimb Championship 1938  
- Clintons Road Christmas Hills -



# 31st ROB ROY Historic & Classic Hillclimb 19 NOV 2023



Competition Entries via Motorsport Australia  
entry system or manually via [robroyhillclimb.com.au](http://robroyhillclimb.com.au)

Competition Commences 9.00am. Admission - \$10 Single entry or \$20 full car  
Full catering provided by Panton Hill CFA who will receive all catering proceeds  
Enquiries - General : Wayne Rushton 0412 339 934 / Competition : John Kelso 0417 398 606



# **Leisure Run November 21 st 2023**

**Craft Coffee Café at the Mile End Homemakers Centre behind  
Bunnings Mile End for Coffee.**



**Then to the Lockleys Hotel for Lunch.**

**Please Notify David Searles if you are attending 0408 700 047**



# [ SENIORS MENU ]

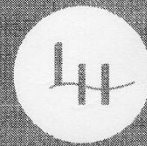

LOCKLEYS  
— HOTEL —

Seniors lunch menu available 11:30-2:30 7 days a week

**\$22**

INCLUDES A GLASS OF  
CHAMPAGNE, HOUSE WINE,  
SCHOONER OF BEER OR SOFT DRINK

## **Chicken Salad**

Lettuce, tomato, cucumber, red onion,  
fetta, grilled chicken & pesto aioli

## **Chargrilled Pork Loin**

Braised cabbage, apple sauce, mash  
potato

## **Crumbed Prawns**

Chips, house salad, tartare

## **Spaghetti & Meatballs**

House made beef meatballs, napoli  
sauce, fresh basil, parmesan sauce

## **Roast Of The Day**

Roast potato, pumpkin, peas, gravy

## **Salt & Pepper Squid**

Chips, house salad, tartare

## **1/2 Beef Schnitzel**

Chips, house salad, choice of gravy  
Add \$3 Parmesan

## **Chicken Schnitzel**

Chips, house salad, choice of gravy  
Add \$3 Parmesan

## **Lambs Fry & Bacon**

Onion gravy, mash potato

## **Fish & Chips**

Battered, crumbed or grilled,  
house salad, tartare

## **Extras**

Side of seasonal vegetables | 4

## **Dessert**

Coffee & Housemade cake | 12



# Technical night 27<sup>th</sup> November 2023

Last one for the year.

The Topic of discussion will be diffs.

Sausage Sizzle before the meeting.

Meeting starts at 7.30 pm

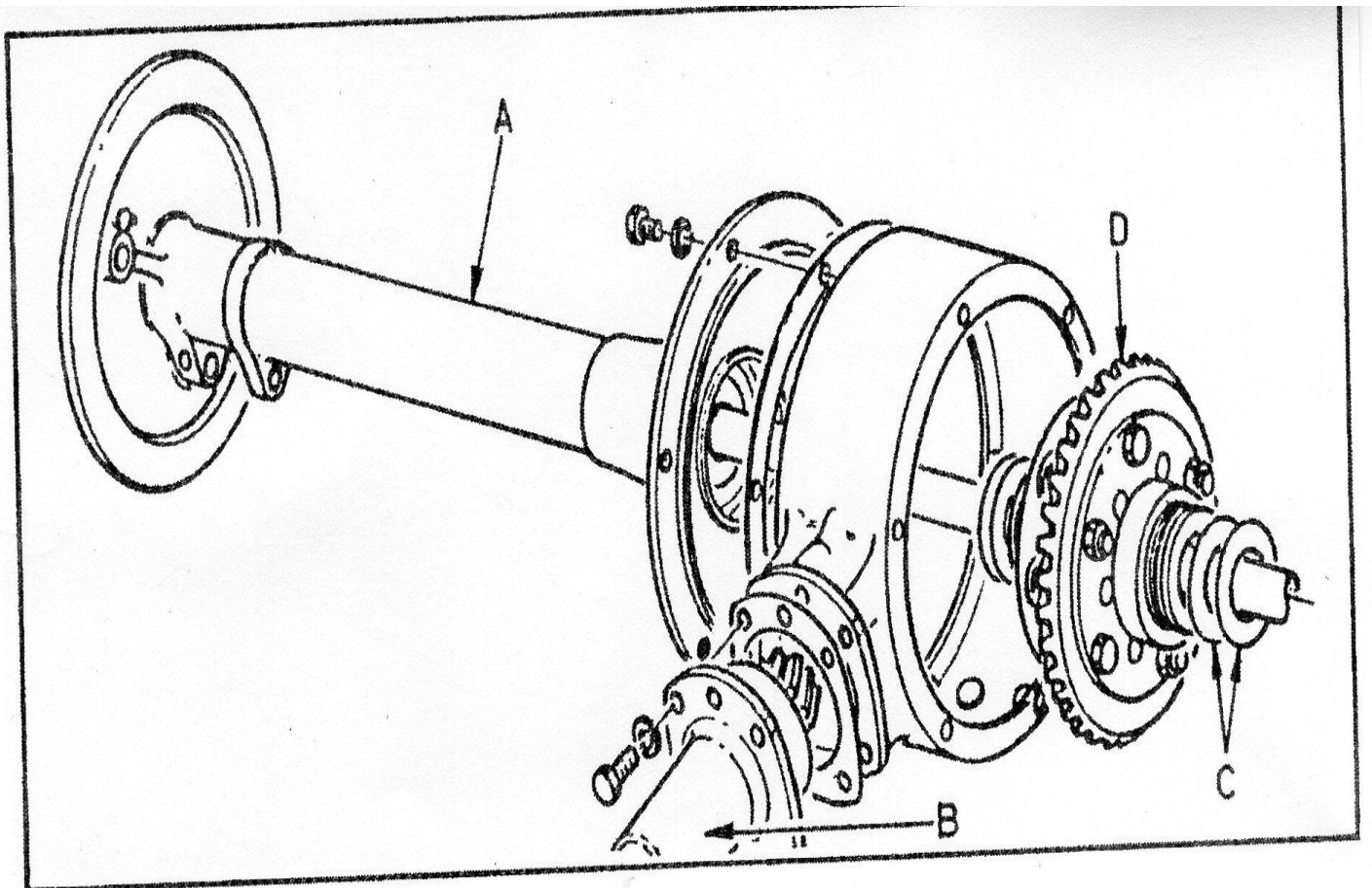





**Mawson Lakes**  
HOTEL & FUNCTION CENTRE

10 Main St Mawson Lakes.

**December 10<sup>th</sup>, 2023**

**Christmas Dinner \$40.00 per head.**

**6.00pm for 6.30pm.**

Please book and pay with the treasurer

**NOW**





## TIME IS RUNNING OUT!

Thank you to the many people who have entered ABD 2024. This year, we have had a few unexpected computer glitches regarding online entries. We apologise for the frustration this has caused.

We do not wish anyone to be disadvantaged and potentially miss out on this great event; therefore, we have decided to extend the original closing from 3/11/2023 to 15 /11/2023. For those still in the process of getting around to it, now is the time to get that entry in!

We have been very fortunate to be able to display many fine examples of British vehicles over the years at Echunga and I am sure 2024 will see our favourites on display plus new entries and restorations making their first appearance at ABD.

We encourage you to bring along your children and grandchildren to this picnic day, and we will be providing some free additional entertainment for the young, (and young at heart).

We are looking forward to hosting you at Echunga next March and showcasing British vehicles to the public.

So, to avoid disappointment, please copy paste to your browser to visit:

<https://www.allbritishday.com/all-british-day-entry-form>

We are looking forward to seeing you and your vehicle at Echunga next March.





**11-15<sup>th</sup> March 2024**

# ALL HISTORIC

26-28 APRIL 2024



FEEL THE PULSE

[SPORTINGCARCLUB.COM.AU](http://SPORTINGCARCLUB.COM.AU)



# 05

MAY  
2024

## INVITATION **OLD CROCKS' RUN**

# 90

YEARS

To celebrate the 90<sup>th</sup> Year of the Old Cocks' Run. All pre 1935 vehicles are welcome to attend this commemorative run from the **Adelaide CBD to Wigley Reserve, Glenelg, on Sunday 5<sup>th</sup> May 2024**. Please mark this event in your calendar. A display of vehicles along with food and drink stalls and other entertainment for the whole family and car enthusiast is planned at Glenelg.

More details soon.

8373 4899



ADELAIDE CBD  
TO GLENELG

**WIGLEY  
RESERVE**



Organised by the Sporting Car Club of SA as part of clubs 90<sup>th</sup> anniversary

[sportingcarclub.com.au](http://sportingcarclub.com.au)



Only two years to go.



**Austin  
Seven**

**NATIONAL RALLY**

**OCTOBER 2027 - MURRAY BRIDGE S.A.**



# Bendigo Swap Meet was held on Saturday 11<sup>th</sup> November 2023

The last Bendigo was 2019 Due to Covid and Flooding in Victoria.

The swap meet has 1500 sites and a number of them were vacant even though all sites were booked. The prediction of 30 degrees on Saturday probably made some people stay away.

Sales must have been good as the ATM machine had run out of money by 9.00am.

A large number of people were there in the morning but by lunchtime the numbers were sparse.

One find we had was the business that redoes seatbelt webbing and they use original materials and colours.



**Buckle Up Seatbelts**

**Mandy & Roderick Pickering**

0493 586 871  
sales@buckleupseatbelts.au  
Facebook: Buckle Up Seatbelts

*formerly Stamps Hot Rod Coloured Seatbelts*

**CUSTOM MADE SEATBELTS**



The other was that Peter Jackson is reproducing gearbox covers for Austin 8's. Peter can be contacted at Old Era Rubber Products.

# From the Austin 7 Club Journals

## 1986

12

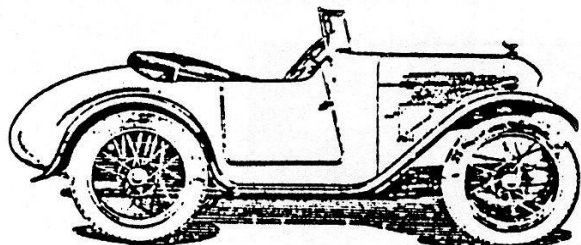

### A7 OWNERS TOURING

### REPORTS

#### BAY TO BIRDWOOD 1986

Well the "Big One" is over once again, and this time it was really BIG!! I never appreciated just how many cars were involved until we neared Glenelg. With cars converging on the Bay Road from all directions. Progress was so slow as we neared the starting point that we actually stopped engines and pushed our cars.

On arrival our party of eight cars were ushered to several different locations, which successfully messed up our plans for a "vintage" breakfast together. I didn't really miss the sausages etc. cooked on a kero stove, but from that point, we only caught up with two of our party all day.

Unice and a friend in "Grandma" and Peter and me in the "Meteor" managed to stay together, and had a very good run, cheered on by the hundreds of spectators from their vantage points in the sunshine, but an unscheduled "loo" stop caused us to be separated again at Birdwood. This time it was getting serious because all of our food and refreshments were in "Grandma's" trunk, and the consequent change of paddocks to remedy this situation was not at all popular with a couple of Army blokes doing the organising, but we eventually settled down, had lunch and looked around the cars, and I doubt if I will ever get another chance to see such a collection in one spot again.

In view of the numbers involved there were bound to be some delays and the suggestion sheets supplied should make interesting reading, but in general I think the organising was good.

The only real annoyance we encountered came not from Rally entrants, but some outsiders in cars and dune buggies, taking advantage of the gap I usually leave to allow for emergency stops with the "Meteor's" not remarkable braking. - (I'm certain the last inch of travel on the brake pedal is somehow connected to the acceleration), and their darting into the gap caused a few anxious moments. Perhaps another brake pedal on Peters side might help because he was certainly going through the actions - not to mention the floorboards.

A great days motoring in perfect conditions, and I wonder what 1988's Rally will be like.

Unice and Bryant Lawson.

# Buy, Sell & Exchange

**ANNOUNCEMENT**



ALL NEW 500 c.c.  
**SPEEDWAY MACHINE**  
FOR 1969

Produced by  
AIRCRAFT CORPORATION OF JAPAN  
AVAILABLE FOR 1969 SPEEDWAY SEASON  
60 b.h.p., 8,500 revs.  
**PRICE COMPLETE \$750.**

Supercharger Optional Extra  
**ADVANCE ORDERS ACCEPTED NOW**  
SOLE REPRESENTATIVE England, America, Australia  
**JOLLY'S MOTOR CO.**  
3 COOPER PLACE, BEAUMONT, S.A.  
Phone 79 4241

7

A new HT Holden in 1969 was \$2326 about 3 times as much as a new speedway bike.



## **Friday Thoughts**

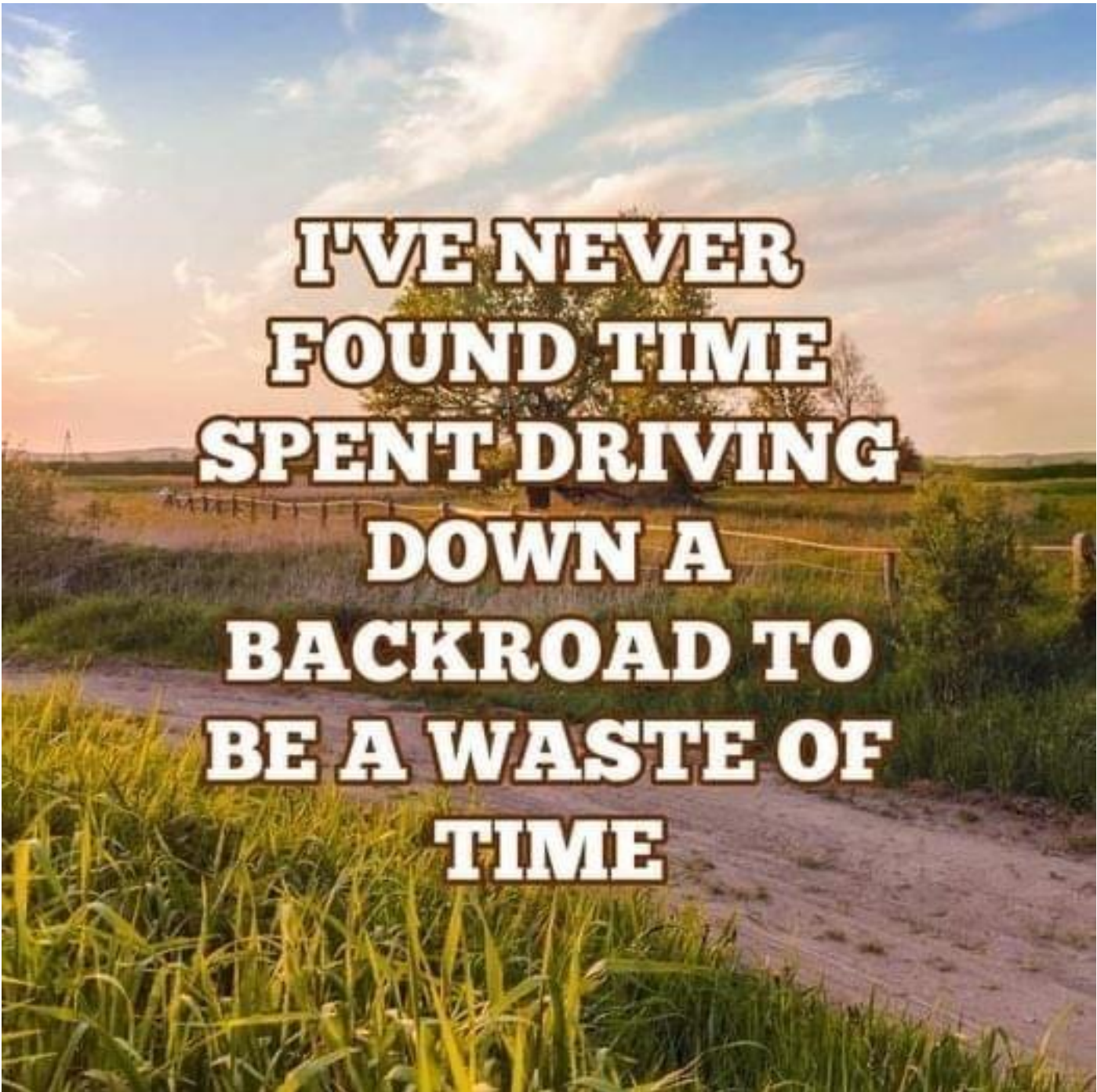

**I'VE NEVER  
FOUND TIME  
SPENT DRIVING  
DOWN A  
BACKROAD TO  
BE A WASTE OF  
TIME**