



Austin 7 Club of S.A.

70th Anniversary 1953-2023

Bulletin Number 159

19.5.23



What's on and What's not.

21.5.23 Cavalcade of Cars Kadina

22.5.23 A7C Technical Night

27.5-28.5.23 Historic Winton

4.6.23 A7CTTM Regularity #3

5.6.23 A7C Committee Meeting

**12.6.23 A7C Monthly Club Meeting at 7.30pm.
preceded by a meal at Clubrooms.**

**17/23.6.23 Austin 7 Club SA Inc 70th Birthday drive
to Farina & Marree.**

18.6.23 A7C Sedan Swap Meet

26.6.23 A7C Technical Night

10.7.23 A7C Monthly Club Meeting at 7.30pm

16.7.23 Burra – Morgan run

18.7.23 A7C Leisure Run

23.7.23 A7C Hills Luncheon

23.7.23 A7C TTM Regularity#4

24.7.23 A7C Technical Night

Please check with the organisers as dates and events may be subject to change.

Page 3 Girl

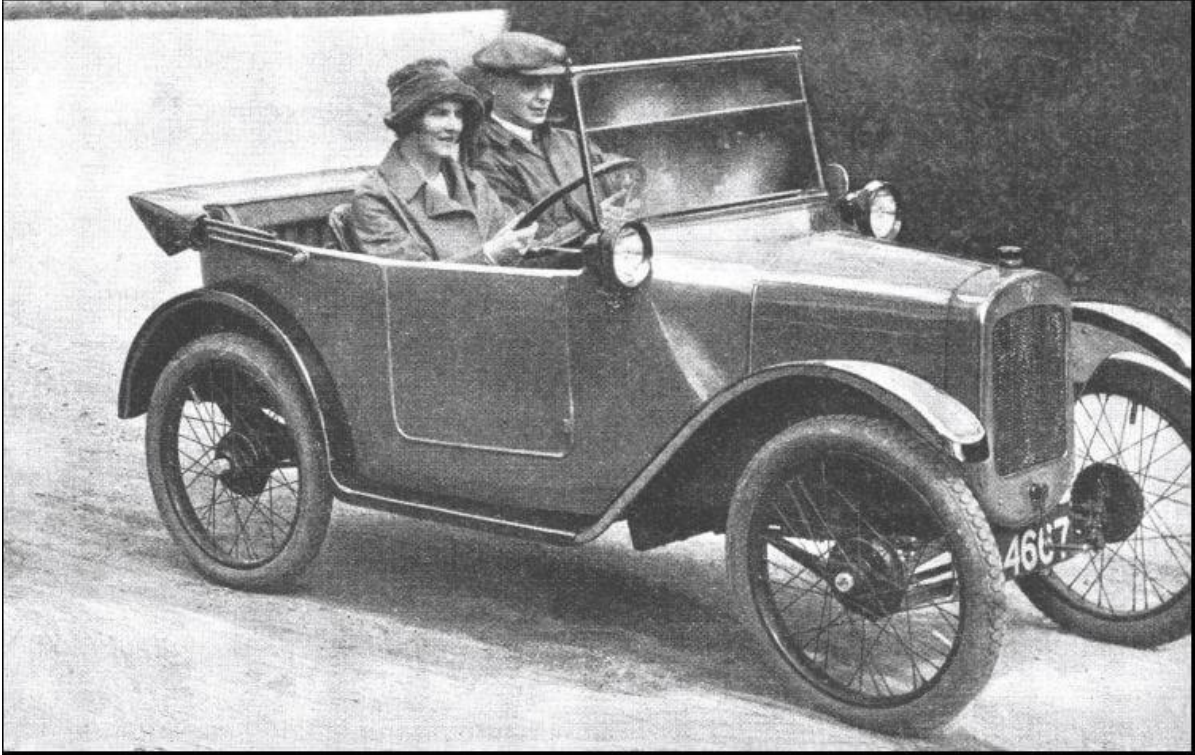

Sports and Specials



Sillier than a Seven

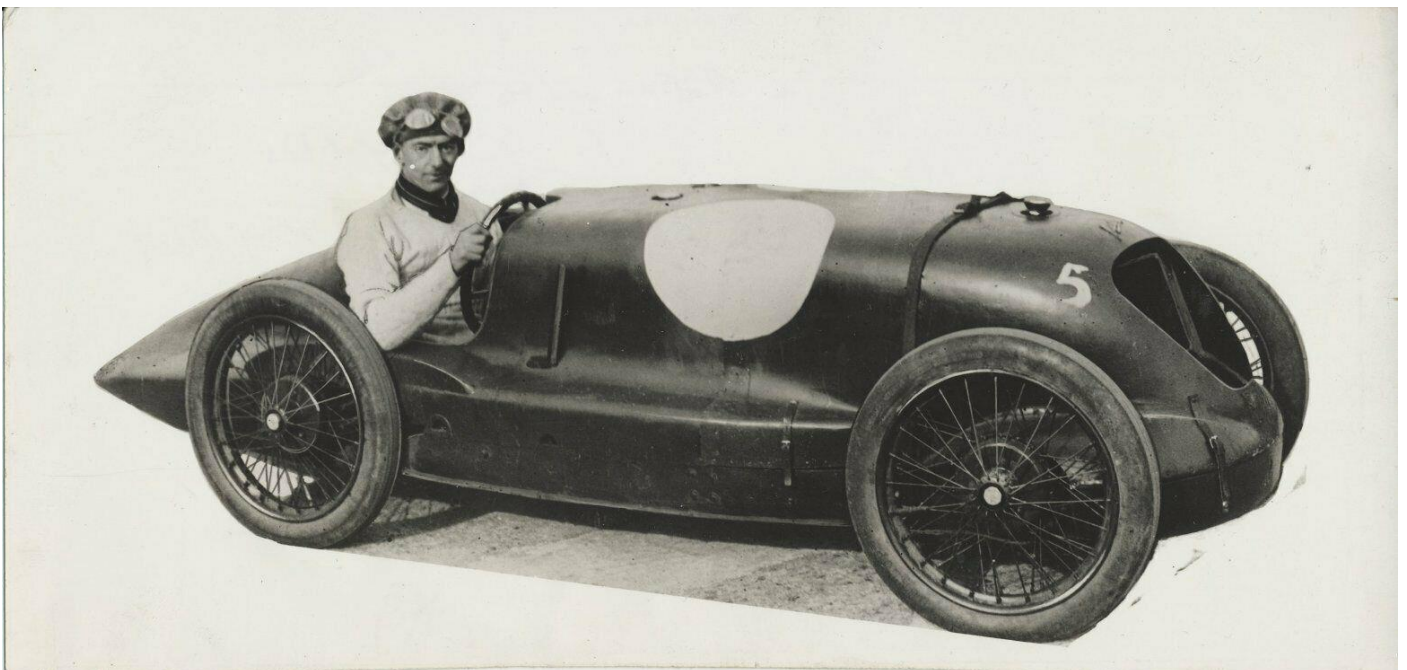



2023 Dates

Our competition dates for 2023 are as follows.

June 4, July 23, Aug 27, Nov 5

All at Mallala





Austin 7 Club of S.A.

Technical Night 22nd May at 7.30pm

262 Tapleys Hills Rd. Seaton

Let's talk Speedsters

Wolf's Perkolilli Car on display

Scotty's new car on display

Non-Members Welcome

Bring along your speed equipment for "Show & Tell".



46th HISTORIC WINTON[®]

Featuring
Pre-1965 Tin Top Regularity

27th and 28th May 2023



www.historicwinton.org

Winton Motor Raceway, Benalla, Victoria



Austin Seven Club Inc. A0003290N | Photo - Neil Hammond



LAST
SUNDAY
OF MAY

CLASSIC & VINTAGE
**SHOW
N'SHINE**

10AM - 2PM
PORT BROUGHTON
FORESHORE

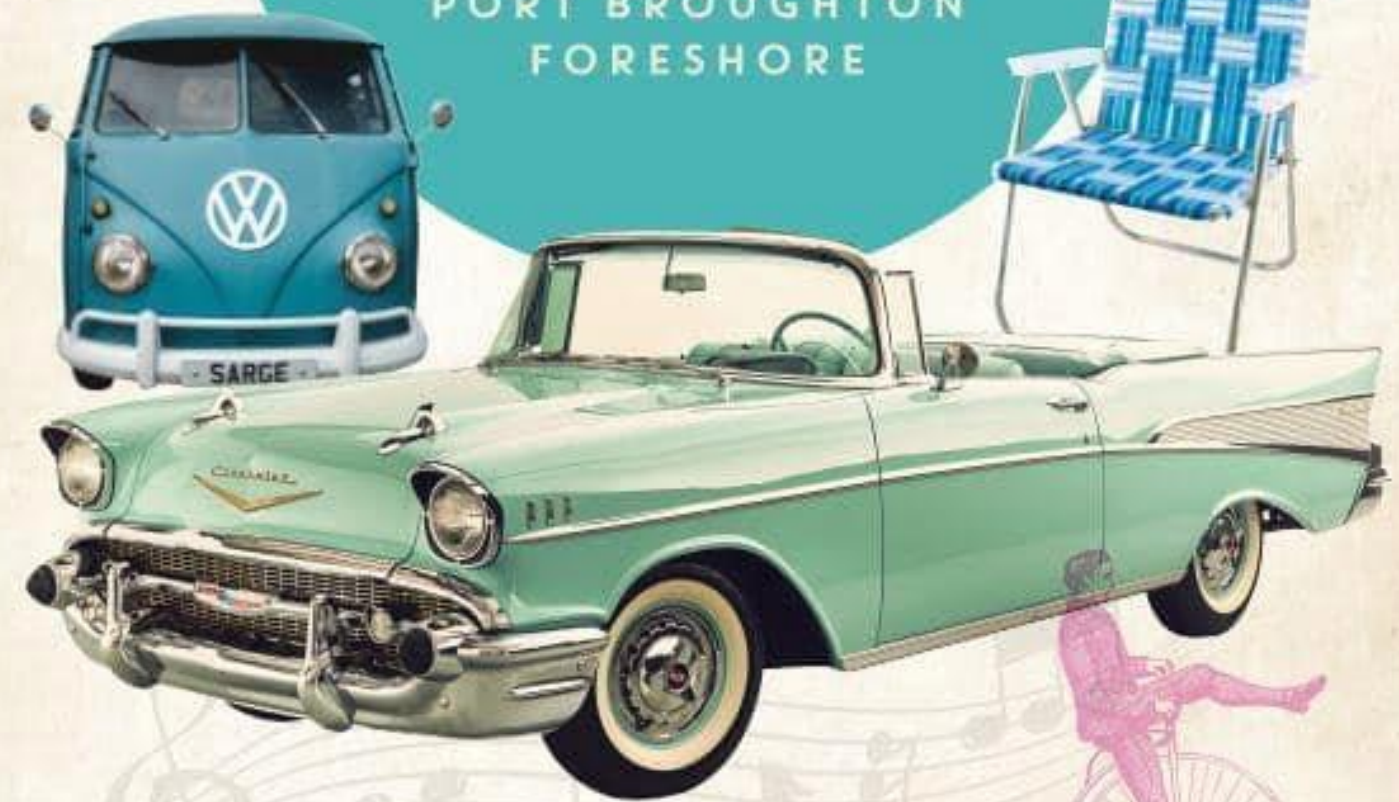

To register a vehicle please contact
Barunga West Council on **8635 2107**
or barunga@barungawest.sa.gov.au

70th Anniversary Austin 7 Club Run to Marree via Farina Bakery and other eateries.

17 to 23 June 2023 – overview of event.

Day 1 Saturday 17 June: Adelaide to Burra 160 km

OVERNIGHT AT: Paxton Cottages. Ph. 0488 513 101

Day 2 Sunday 18 June Burra to Blinman 342 Km

OVERNIGHT AT Blinman Hotel Ph. 08 8648 4867

Day 3 Monday 19 June Blinman to Marree 214 km

Next two nights at Marree Hotel Ph.08 8675 8344

Day 4 Tuesday 20 June At Marree, “

Return journey.

Day 5 Wednesday 21 June Marree to Hawker

OVERNIGHT AT Hawker Hotel. Ph 08 8648 4102 Kms 271

Day 6 Thursday 22 June

OVERNIGHT AT Paxtons, Burra 273 Kms

Day 7 Friday 23 June

Burra to Adelaide 160 km Total Return Journey 700 Kms

Day 5 Wednesday 21 June ----- Hawker Hotel 08 8648 4102

When you have confirmed your accommodation, please let me know on dsearles10@bigpond.com so that I can monitor progress of numbers coming on this event.

Thank you

David Searles

BURRA - MORGAN RUN

*A weekend of motoring
nostalgia & adventure*



Come and see the wonderful
collection of historic vehicles on

July **16** 2023

Cars will be lined up at Paxton Square
Cottages, Burra from 8.00am
to be flagged off at 9.30am

FOR MORE INFORMATION CONTACT:
ROGER BOEHM 0437322734 OR PAUL WILSON 0419869109

Austins over Australia 2024

7th March -11th March 2024

<http://www.amvcnsw.com.au/aoa/Expression%20of%20Interest%20AOA%202024.pdf>



Expressions of Interest forms available from Martin Lewis (0414 727 893) so you will receive newsletters as they are issued by the organisers.

If you are even slightly interested, please advise Martin by 30th April so tentative accommodation bookings can be made – no obligation at this point.



Austins Over Australia 2024

Thursday 7th March to Monday 11th March 2024
in Orange, NSW



NEWSLETTER No. 1

28/3/2023

With under a year to go we would like to give fellow "Austineers" an update as to the progress on AOA2024

Orange is a significant regional centre with a population of over 40,000 and is renowned for its gourmet wineries, award winning restaurants, and magnificent gardens. The trees will be revealing their vibrant autumn colours when we are there. Day temperatures average a pleasant 24^o with cool 11^o evenings.

To date we have over 100 Expressions of interest and support from the locals has been extremely positive.

There are many types of accommodation options in Orange and we suggest you book early with your chosen provider to avoid disappointment. Budget accommodation is extremely sought after.

Event headquarters will be The Orange Function Centre but, to avoid traffic congestion, not all outings will start there. Final run details along with registration forms and meal arrangements will follow in a later newsletter. Daily runs will be on sealed roads excluding potholes and roadworks which are out of our control and avoiding highways where possible. Lunches will be available on Friday and Saturday.

We propose registration will be at The Orange Function Centre on Thursday afternoon with a full meet and greet meal later that evening at the same venue.

On Friday 8th. We're off to Millthorpe via historic Carcoar. (100k return)

Saturday 9th. We will meet at Lake Canobolas then out to Molong. (75k return)

Sunday 10th. Display day in central Orange.

Followed by an official dinner and presentations at Orange Ex Services Club.

Monday 11th. On our last day we will visit Abercrombie House in Bathurst. (56k one-way) This 1870's home is an Australian treasure and the owners, the Morgan family, have had an association with Austin Sheerlines for many years. Several cars are displayed on the property. A tour of the house and a substantial morning tea will be offered.

AOA2024 will officially conclude at Abercrombie House. Entrants can choose to explore Bathurst, head home, or return to Orange for another night with friends.

Looking forward to meeting old friends and making new ones

Regards

Tony Groom

AOA 2024 Director

0412 036 774

British Classics Tour McLaren Vale to Victor Harbour. 7th May 2023

Jim Henderson and David Biven had a top day with some 160 vehicles driving from McLaren Vale via Old Willunga Hill, Nankita, Finniss, Goolwa and back to Victor Harbor last Sunday. A cold start but glimpses of sunshine before display at Victor Harbor.

“Lettuce Leaf” had a good run being the only old Austin in the group. No Austin 7’s as they were all at Hahndorf for the Pre War run.







Lettuce Leaf Driven by David Biven.

Pre War Austin 7 Club run to Hahndorf

6-8th May 2023



Coffee and Cars on the Coast 14.5.23





Old Adelaide



St Leonards Inn 1955

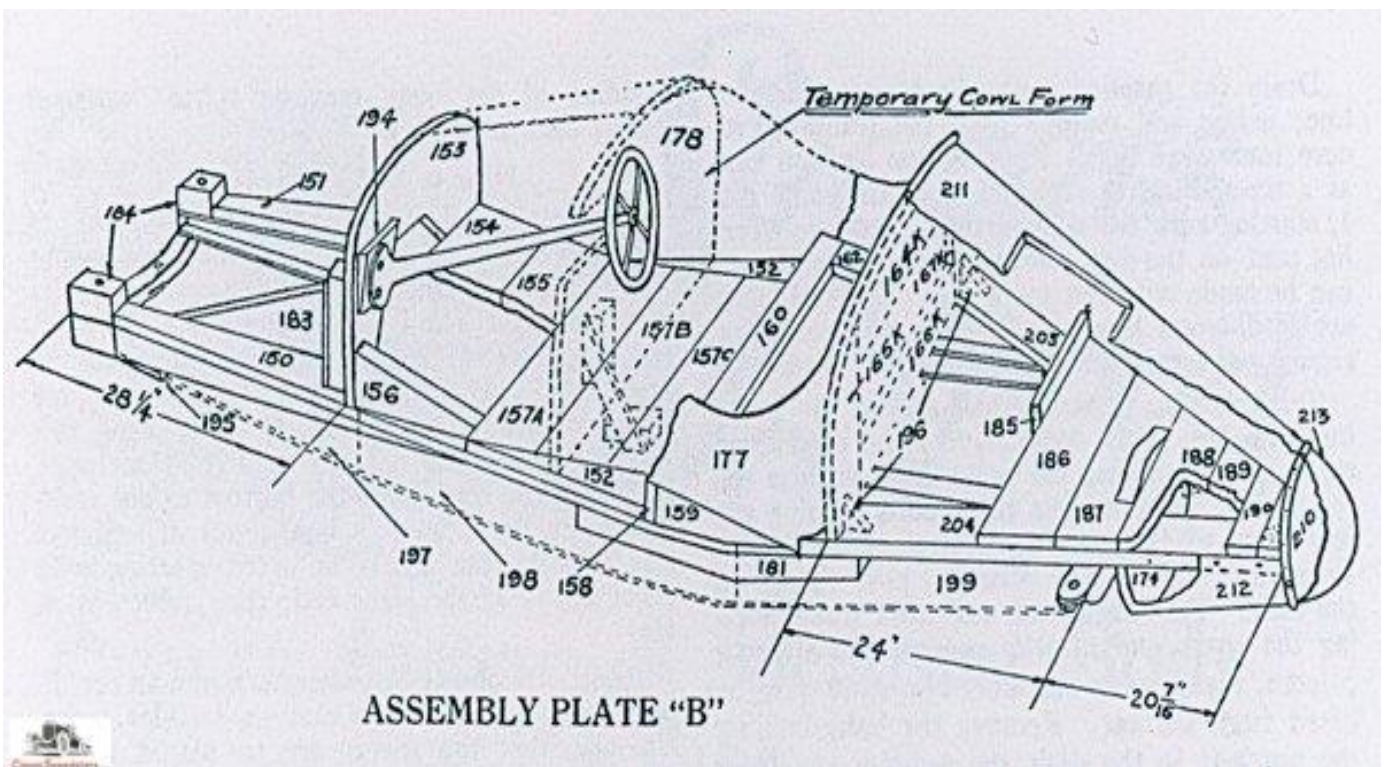
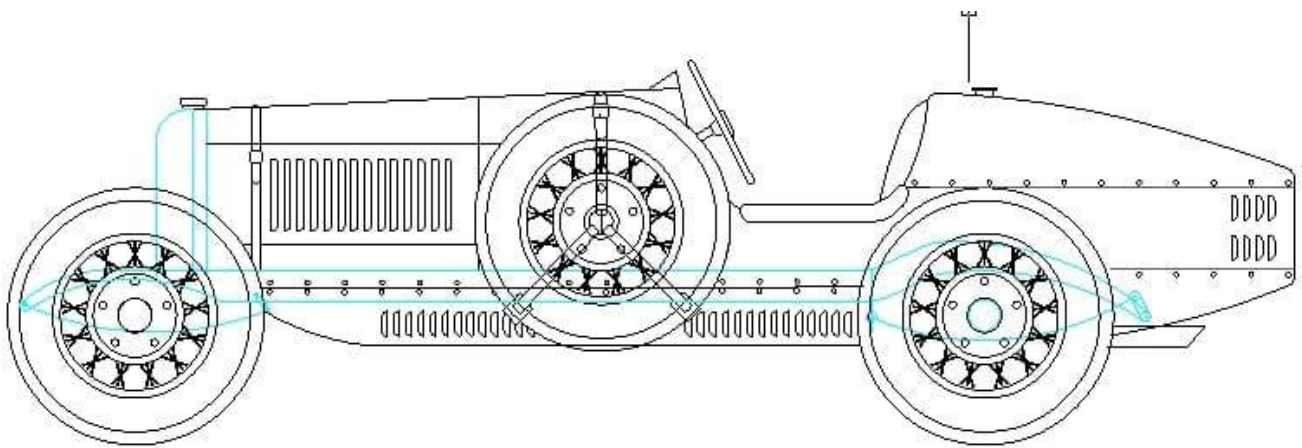
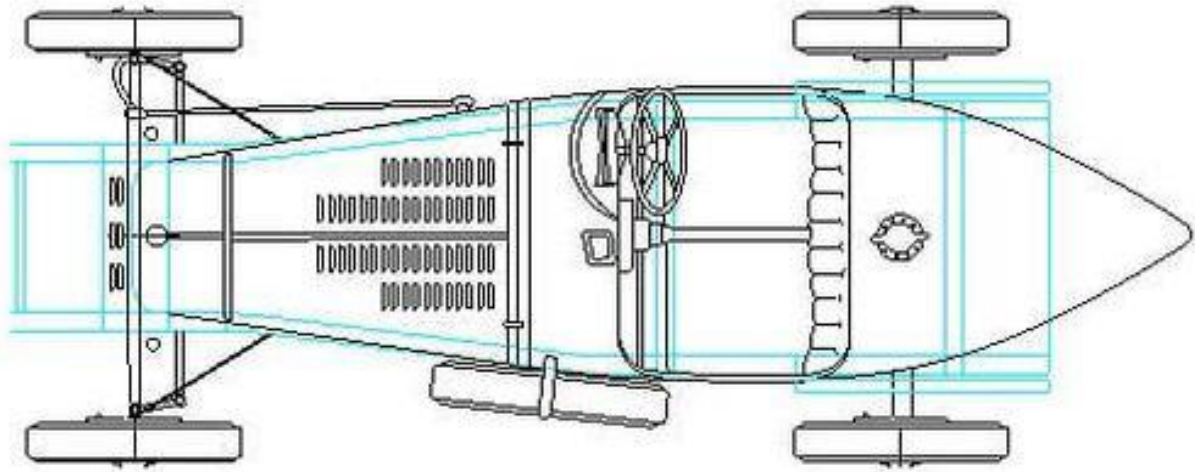

Some of the Austin 7's that raced at Perkolillie in September 2022. Write ups are from the program.

58.

AUSTIN SEVEN

Angelo Fiora bought a copy of the Perkolilli "bible, "Red Dust Racers", at the Kalgoorlie Museum about five years ago, and was inspired to build a car for the Red Dust Revivals.

"As we have had an interest in Austin Sevens for a while, our car was always going to be designed around a 1930s Austin Seven sports special," he said. "We had previously built an Austin Seven van, as well as motor bikes, trikes and other cars."

The car started as a burnt-out Austin Seven Ruby wreck. After stripping it down about a year ago, the Fioras restored the rolling chassis and made a new floor pan. "We dismantled and rebuilt the motor with extractors, a Ricardo head and a new SU carby. As our motor has a Ricardo head, we decided to replicate Bruce McLaren's first race car that's in the McLaren Museum in England. (Also, Daniel Riccardo is now racing for McLaren, so it made sense!)"



"Next, we built a new body. The body was scaled from a photo of Bruce McLaren's first race car and we built our car as close as practical to that car. My brother, Mick Fiora, designed and fabricated the body with a little help from me," said Angelo. "The internal panels are aluminium and ready to fit once the body is painted."

59.

AUSTIN SEVEN

When Bruce McLaren was 13 years old, his father bought him an Austin Seven in pieces. Instead of rebuilding it as a road car, he built a racing car instead. He raced the car for the first time in 1954.

About 30 years later, Hugh Fryer also built this 1929 Austin Seven in New Zealand from a pile of parts. Just like Bruce, it took Hugh two years to build. The body was shaped by Gordon Routledge who was the inspiration and motivation for the 18 year old Hugh to build the car, to keep focused and take it though to completion.

The car was finished in time to compete in the Ashley Forest Hill Climb in April 1980. It was then road registered in time for a three day rally called Irishman's in the high country of the South Island in June 1980.

The car was brought over from New Zealand in 1996 and competed in the first Northam 'Round the Houses' in 1999. It was a regular entrant for the next five to six years as well as clocking up many road miles. It was regularly driven from Perth to Northam on the Saturday for the Hill Climb, Round the Houses on the Sunday then



driven home, all on one 4-gallon tank of fuel! Another competition highlight was Perkolilli in 2014. Even though the event was shortened due to rain it was great fun.

Over the years it has been a very reliable car and, having standard Austin Seven running gear, is easy to maintain. When Hugh's children were small, he used to taken them for drives, two at a time. Now 20 years later, it's great to see them drive the car for themselves.

56.

Buy, Sell & Exchange

Keep Baby SAFE with
a "Lull-A-Baby" Car Hammock

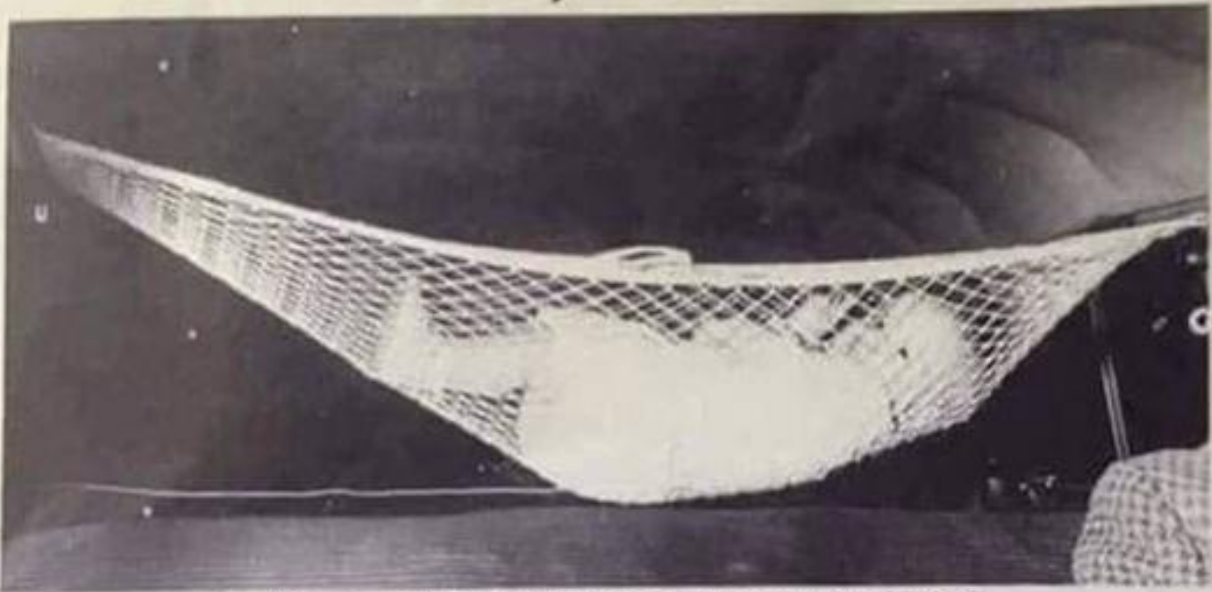

• Baby constantly visible; rear view vision not impaired.

**SAFEST, MOST COMFORTABLE CAR BED
EVER MADE**

**FITS ANY HARDTOP CAR
ONE-MINUTE INSTALLATION**

YOU CAN PURCHASE A "LULL-A-BABY" CAR HAM-
MOCK FROM YOUR LOCAL DEALER OR PURCHASE
IT AT 518 Lighthouse Avenue, Monterey, California.

RETAILS FOR ONLY

\$ **6⁹⁵**

on the Monterey Peninsula.

For Auction

20th May 2023



Vintage Austin 7 Race Car, Known History, Austin 8 Engine,
Down Draught Carburetor, Side Exit, Four into One Exhaust,
Including Race Trailer.

[AUSTIN 7 | Scammells \(scammellauctions.com.au\)](https://scammellauctions.com.au)

For Sale



Austin 7 1932 in need of restoration, not running motor in pieces some new parts see photos. Spare motor in pieces also.

Car is an old restoration that stopped running 20 years ago. See photos for condition. top in good condition, tonneau in good condition.

inspection recommended and welcomed.

Advertised on Ebay

Rob Underwood Goolwa S.A. 0431 822 937.

For Sale

One set of Pistons with rings to suit an
Austin 8 2.235 +.060



Phone Karl 0412 344 198

Friday Funny

